



[HOME](#) > [ENGINEERING & TECHNICAL](#) > [TECHNICAL ARTICLES](#) > [INTRODUCTION TO PULSATION DAMPENERS / SURGE SUPPRESSORS](#)

Technical Articles

August 8, 2016

Introduction to Pulsation Dampeners / Surge Suppressors Innovative Design Provides Multiple System Safeguards

Functions:

1. **Pulsation Dampener** smooths pump flow
2. **Surge Suppressor** absorbs shocks and vibrations
3. **Water Hammer Arrestor** eliminates dangerous pressure spikes caused by quick closing valves
4. **Inlet Stabilizer** enhances pump performance and longevity
5. **Accumulator** releases stored fluid during unwanted pressure drops
6. **Expansion Tank** protects system from thermal volume increases

Design Features:

- Large inlet improves response
- Inlet screen protects bladder with minimal flow obstruction
- Dual seal channels protect against air and system leaks
- Top quality thermoplastics and elastomers resist chemical attack,

- protect system purity
- o No wetted metal parts



Description:

PDS is available in three capacities/sizes: 10 cubic inch capacity with a 1" NPT process connection, 50 cubic inch capacity with a 2" NPT process connection, and 180 cubic inch capacity with a 3" NPT process connection. Body materials are choice of Geon PVC, CPVC, Natural Polypropylene, or Kynar PVDF. Inlet screen and dome top match selected body material. Bladder material is EPDM or FKM. Air inlet valve and gauge isolation valve (non-wetted) are brass. Fasteners are stainless steel.

For other material or connection requirements, please consult factory.

How it Works:

Pulsation Dampener and Surge Suppressor will steady a pulsing flow caused by diaphragm pumps, piston pumps, peristaltic pumps and other quick flow interrupting equipment. The PDS will steady a vibrating pointer of a pressure gauge or flow meter under flowing conditions. When used properly, quick pulsating flows will be greatly reduced preventing the following flow control problems:

- Prevents Fatigue of all Pipes and Inline Equipment.
- Ruptured Piping, Gaskets and Seals

- Leaking and Weakened Connections
- Pipe Vibration and Noise
- Damaged Valves and Filters
- Damaged Pressure Regulators and Gages
- Loosened Pipe Hangers and Supports
- Premature Failure of other Equipment and Devices
- Prevents Splashing and Foaming of Fluids

Pulsation dampening provides the added benefit of smoothing the output supplied by many types of pumps, especially double diaphragm pumps and metering pumps. This provides a steady, uninterrupted supply to points of use, which will greatly enhance system productivity, prolong pump life, and prevent splashing and foaming.

Water Hammer Arrestor When used properly, water hammer will be greatly reduced to just a few percentage points of the spike that the system would have without using the PDS. This helps prevent the following flow control problems, as per the Plumbing and Drainage Institute Standard PDI-WH 201:

- Ruptured Piping
- Leaking Connections
- Weakened Connections
- Pipe Vibration and Noise
- Damaged Valves
- Damaged Check Valves
- Damaged Water Meters
- Damaged Pressure Regulators and Gages
- Damaged Recording Apparatus
- Loosened Pipe Hangers and Supports
- Ruptured Tanks and Water Heaters
- Damaged filters
- Premature Failure of other Equipment and Devices

Inlet Stabilizer AKA “Suction” Stabilizer — Installed as close as possible to the pump inlet, the PDS will take in liquid when the system is pressurized. If the dome is properly charged with compressed air, the PDS will expel the liquid back into the pipeline when the pump draws liquid and pressure drops. This repeated action ensures a continuous supply of liquid to the pump, reducing strain on the pump and greatly improving pump efficiency. Used in combination with a PDS on the discharge, in most cases the pump will supply a smooth, steady flow at a constant pressure and prevent the following pump related problems:

- Cavitation and “starvation”
- High frequency pressure waves
- Incomplete filling of pump chambers
- Uneven flow and pressure
- Pump friction and overheating
- Pump damage and premature failure

Accumulator As with the inlet stabilizer function above, the PDS will take in liquid when the system is pressurized. If the dome is properly charged with compressed air, the PDS will expel the liquid back into the pipeline when pressure drops. This cycle is automatic, or the liquid and line pressure can be retained and released as needed simply by using a blocking valve between the PDS and the piping tee. The accumulated liquid and pressure could be held for unexpected power outtages or other system failures, and then used to complete a cycle, retained for backflush during scheduled maintenance, or any other requirements when the regular process is off or interrupted. When the intended use of the PDS is solely as an accumulator, the blocking valve need not be a

full port design.

Thermal Expansion Tank Liquid temperature generally increases in a flowing condition. It can also increase due to processes or external factors that transfer heat to the media. When temperature increases and liquid — which is non-compressible — expands in a closed system, the results can be catastrophic. The PDS can be used as a simple expansion tank in many applications where anticipated expansion would be less than the stated capacity of the unit.

Important: Please note that Series PDS is designed to operate as a pressurized vessel. Proper precaution should be taken to ensure safe installation and operation; read the installation instructions carefully prior to use. The unit should be charged with regulated compressed air or nitrogen only. Oxygen must not be used. The gauge isolation valve should be closed prior to opening the system connection valve. Failure to observe all precautions could result in system failure, leaks, explosion, property damage, personal injury and/or fatalities.

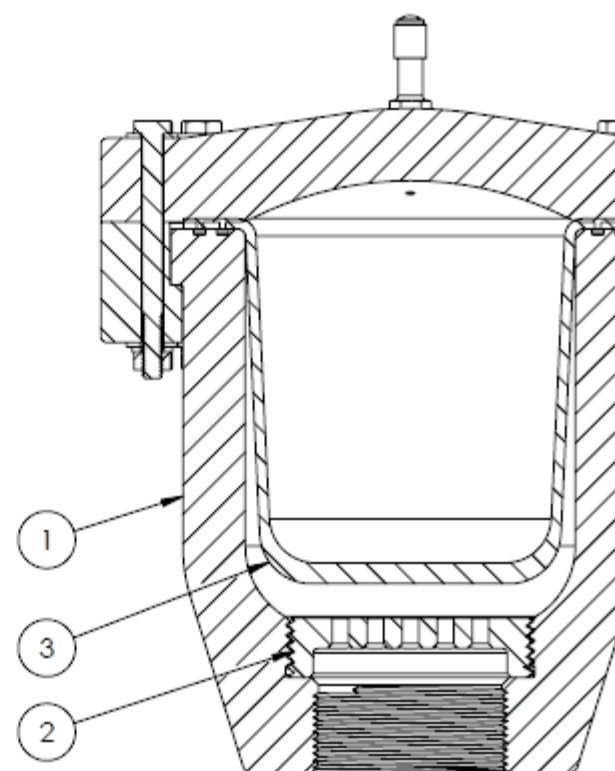
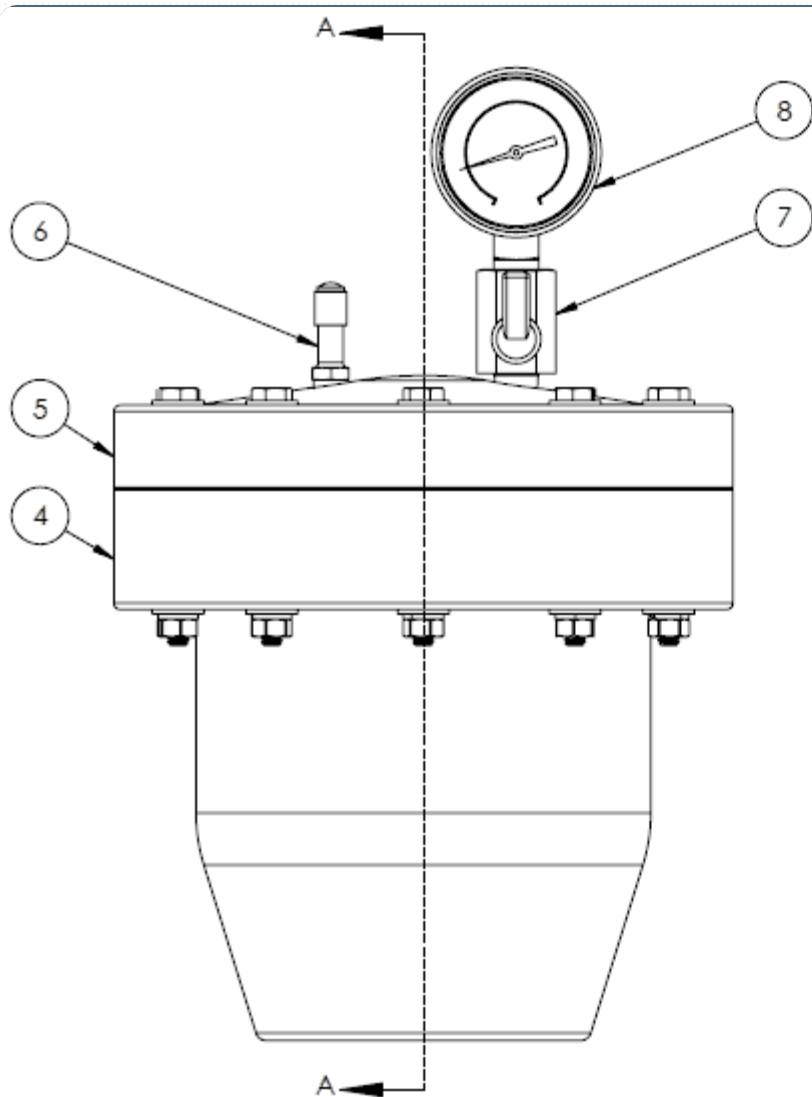

SECTION A-A

ITEM NO.	DESCRIPTION
1	BULB BODY
2	INLET SCREEN
3	BLADDER
4	CLAMP RING
5	DOMES TOP,
6	AIR INLET VALVE, PDS
7	GAUGE ISOLATION VALVE, PDS
8	0-160 PSI PRESSURE GAUGE, LOWER MOUNT
9	STAINLESS FLAT WASHER
10	SS LOCKWASHER
11	SS CAP SCREW HEX HEAD
12	SS HEX NUT

Dimensions & Ordering Information:

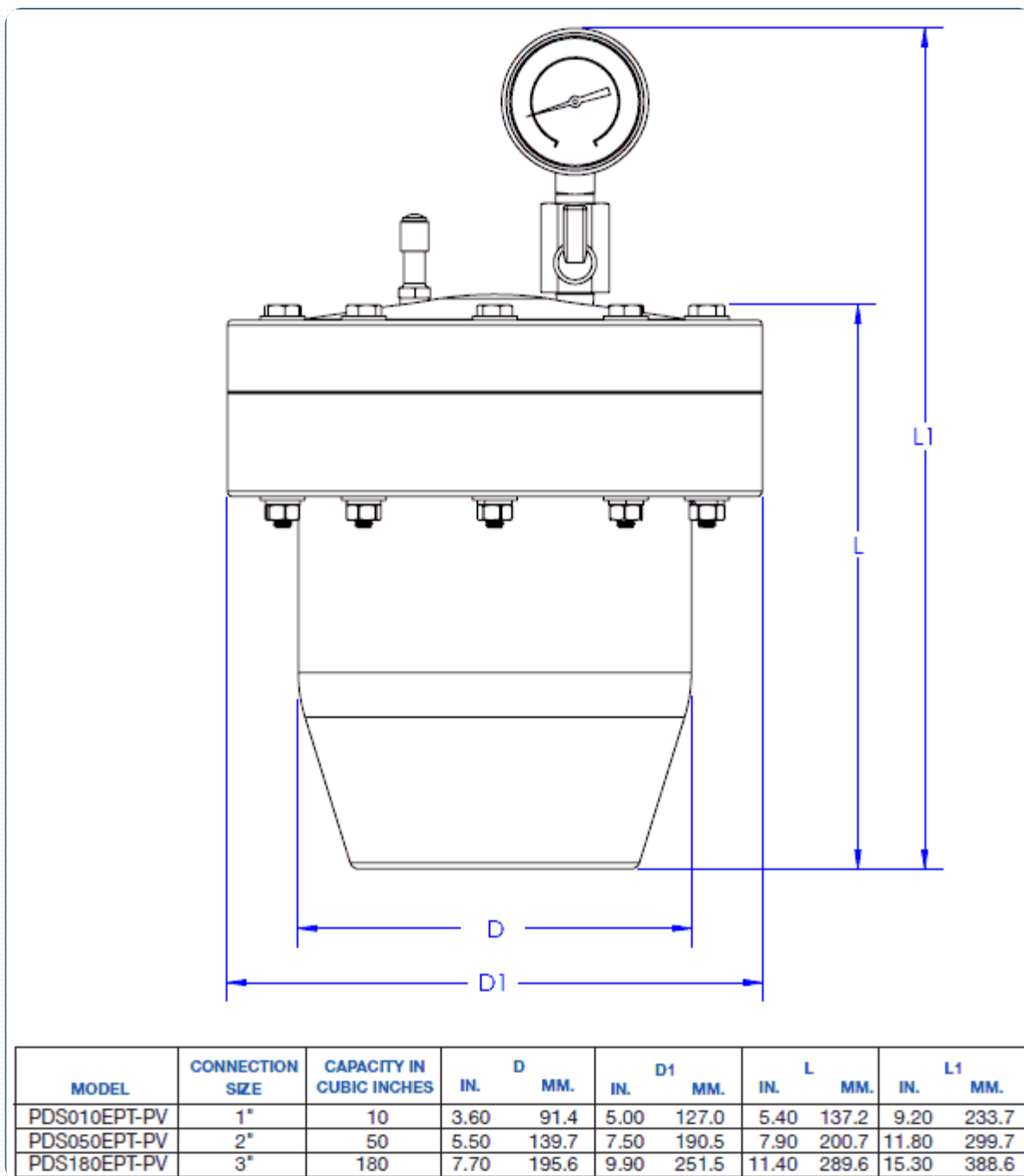

Part number includes series prefix, capacity, seal material, process connection, and body material:

PDS(series) **010**(capacity) **EP**(seal material) **T**(process connection) – **PV**(body material)

- For FKM seals, use “V” for example PDS010VT-PV; for EPDM seals use “EP” as shown above.
- Standard connections are threaded and indicated by the “T” after the seal material.
- For CPVC body, use “-CP” for example PDS010VT-CP; for Natural Polypro use -PP, for Kynar PVDF use -PF. For PVC body use “-PV” as shown above.
- For optional gauges, connections or materials please consult factory.

Sizing the PDS

Selecting a PDS Dampener(s) with sufficient capacity or volume is determined by a number of factors depending on the application (pulsation dampening or water hammer arrest).

To Calculate Size When Used As Pulsation Dampener :

K: Type of dosing/piston metering pump. Use appropriate factor...
Most Common Simplex: Single Acting = .60; Double Acting = .25
Duplex: Single Acting = .25; Double Acting = .15
Triplex: Single Acting = .25; Double Acting = .15
For double diaphragm pumps use K=0.30

V: Volume/Stroke of dosing pump in cubic inches

P: System mean operating pressure

Pmax & Pmin: Min and max desired operating pressure

n: Factor based on dampener charge
For Compressed Air use 1.0; for Nitrogen use .714

Calculation:

$$C = \frac{(V) \times (K) \times (P/P_{min})^n}{1 - (P/P_{max})^n}$$

C = Required Dampener Capacity in Cubic Inches

PDS for pulsation dampening may be determined by the type of pump, pump volume, etc. and PDS for water hammer arrest may be determined by pipe size, flow rate, etc. as shown on the following selection tables.

The suitability of the PDS as defined by the following tables may not be appropriate for every application for a variety of factors, including but not limited to liquid velocity, presence of entrained air or gas in the pipeline, distance from pump or quick closing valves, specific gravity and/or liquid viscosity, temperature, variances in pressure, and a host of other factors. For applications in question, please use the formula shown above.

As a general rule, the charts below will eliminate about 75% of pump pulsation. The formula above solves for a higher capacity than those listed in the charts, and will eliminate about 98% of typical pulsation in the same system.

PERISTALTIC PUMP

PORT SIZE	(HOSE PUMP) GALLONS PER REVOLUTION	RECOMMENDED POM DAMPENER
1/4"	UP TO 0.010	PDS010
3/8"	UP TO 0.010	PDS010
1/2"	UP TO 0.010	PDS010
3/4"	UP TO 0.025	PDS050
1"	UP TO 0.075	PDS050
1-1/2"	UP TO 0.4	PDS180
2"	UP TO 0.9	(2)PDS180

AIR OPERATED DOUBLE DIAPHRAGM PUMP

PORT SIZE	RECOMMENDED POM DAMPENER
1/4"	PDS010
3/8"	PDS010
1/2"	PDS050
3/4"	PDS050
1"	PDS050
1-1/4"	PDS180
1-1/2"	PDS180
2"	(2) PDS180

SINGLE ACTING PISTON METERING PUMP

PORT SIZE	MINIMUM PUMP CYCLES PER MINUTE	MINIMUM REQUIRED BACK PRESSURE PSI	VOLUME PER STROKE GPM	RECOMMENDED POM DAMPENER
1/4"	40	27	0.03	PDS010
1/4"	40	35	0.037	PDS010
1/4"	30	30	0.024	PDS010
1/4"	20	20	0.062	(2) PDS010
1/4"	15	25	0.076	(2) PDS010
3/8"	40	25	0.075	(2) PDS010
3/8"	30	25	0.066	(2) PDS010
3/8"	20	30	0.086	(2) PDS010
1/2"	30	15	0.085	PDS050
1/2"	30	12	0.09	PDS050
1/2"	15	15	0.085	PDS050
1/2"	6	8	0.085	PDS050
3/4"	30	15	0.12	PDS050
3/4"	30	12	0.2	(2) PDS050
3/4"	15	10	0.25	(2) PDS050
3/4"	6	15	0.32	(2) PDS050
1"	30	15	0.12	PDS050
1"	15	10	0.25	(2) PDS050
1"	6	15	0.32	(2) PDS050
1-1/2"	24	15	0.19	(2) PDS050
1-1/2"	18	10	0.32	PDS180
1-1/2"	12	16	0.41	PDS180
2"	24	10	0.28	PDS180
2"	16	14	0.33	PDS180
2"	10	170	0.548	(2) PDS180

ONE PDS050 UNIT CAN BE USED INSTEAD OF 2 PDS010 UNITS AND ONE PDS180 CAN BE USED INSTEAD OF 2 PDS050 UNITS.

NOTE THAT "MINIMUM PUMP CYCLES", "MINIMUM BACK PRESSURE", AND "VOLUME" RECOMMENDATIONS ARE FOR NEAR SMOOTH OUTLET FLOW CONDITIONS.

AS A GENERAL RULE, THESE CHARTS WILL ELIMINATE APPROXIMATELY 75% OF TYPICAL PULSATIIONS. FOR GREATER REDUCTIONS, USE THE FORMULA PROVIDED AT PLASTOMATIC.COM.

WATER HAMMER ARRESTOR SELECTION CHART ALL FLOW RATES ARE FOR 5 FEET / SECOND

SCD. 80 PIPE DIA.	LENGTH OF PIPE (FEET)	FLOW RATE (GAL. / MIN.)	RECOMMENDED POM DAMPENER	
			60 PSI LINE PRESSURE	100 PSI LINE PRESSURE
1/4"	25	1.02	PDS010	PDS010
1/4"	50	1.02	PDS010	PDS010
1/4"	100	1.02	PDS010	PDS010
1/4"	200	1.02	PDS010	PDS010
3/8"	25	2.03	PDS010	PDS010
3/8"	50	2.03	PDS010	PDS010
3/8"	100	2.03	PDS010	PDS010
3/8"	200	2.03	PDS010	(2) PDS010
1/2"	25	3.41	PDS010	PDS010
1/2"	50	3.41	PDS010	PDS010
1/2"	100	3.41	PDS010	(2) PDS010
1/2"	200	3.41	PDS010	PDS050
3/4"	25	6.42	PDS010	PDS010
3/4"	50	6.42	PDS010	(2) PDS010
3/4"	100	6.42	PDS010	PDS050
3/4"	200	6.42	(2) PDS10	PDS050
1"	25	10.7	PDS010	PDS010
1"	50	10.7	PDS010	(2) PDS010
1"	100	10.7	(2) PDS010	PDS050
1"	200	10.7	PDS050	(2) PDS050
1-1/2"	25	26.67	PDS010	PDS050
1-1/2"	50	26.67	(2) PDS010	PDS050
1-1/2"	100	26.67	PDS050	(2) PDS050
1-1/2"	200	26.67	(2) PDS050	PDS180
2"	25	44.8	(2) PDS010	PDS050
2"	50	44.8	PDS050	(2) PDS050
2"	100	44.8	(2) PDS050	PDS180
2"	200	44.8	PDS180	PDS180 + PDS050

Note that (1) PDS050 can be used instead of (2) PDS010 water hammer arrestors.

Note that (1) PDS180 can be used instead of (2) PDS050 water hammer arrestors.

Always set bladder preload pressure at 5 psi less than line pressure when flowing.

For flow parameters not listed consult factory.

NOTE: Please remember that the user is ultimately responsible for the suitability of a PDS Dampener for any given application. An improperly specified or installed dampener can result in leaks, fugitive emissions, explosion, catastrophic failure, property damage, injury or death.

Installation Notes

The sizing charts provided are general guidelines. If the dampening in a particular system is not sufficient, an additional or larger unit may be required to meet the requirements of a particular system. POM dampeners, water hammer arrestors, and inlet stabilizers have inlet ports larger than other competitors to transfer fluid and forces

faster. This allows slightly smaller and lighter units to be used as opposed to larger and heavier ones.

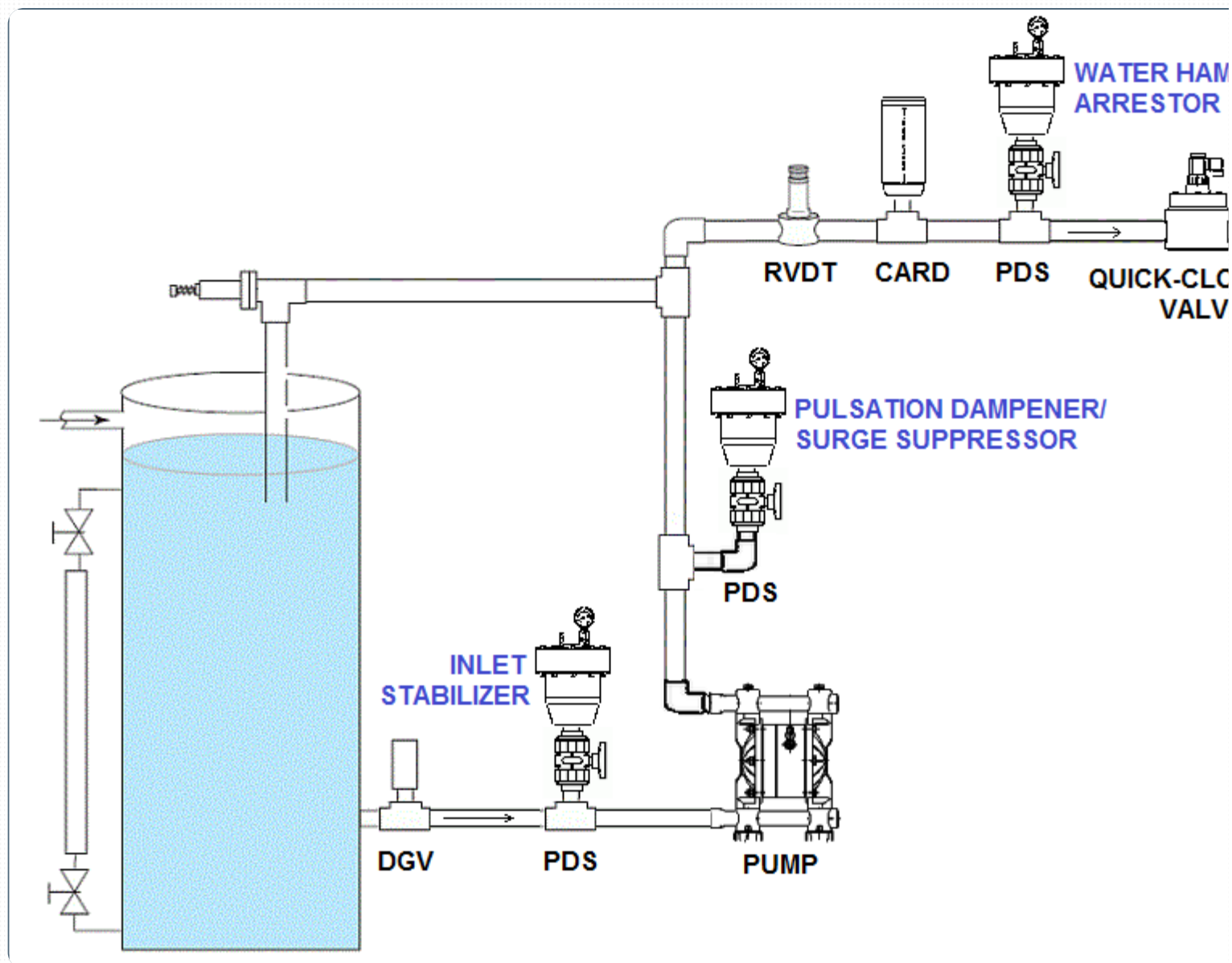

There are many different locations within a pipeline where pulsation dampeners/surge suppressors/suction stabilizers etc. should be installed. In all cases a blocking valve should be installed between the PDS unit and the piping tee. If the PDS is to be used solely as an accumulator, the blocking valve can be a reduced port or throttling design if desired. For all other uses the blocking valve should be a full port design such as a ball valve. The installation tee should be one pipe size larger than the system to facilitate pressure transfer. Generally speaking, the PDS should be installed as close as possible to the application need. In other words, an inlet (suction) stabilizer should be near the inlet of the pump. A pulsation dampener should be near the outlet of the pump. A water hammer arrestor should be near any quick-closing valves. As an expansion tank, the PDS should be close to the source of temperature increase.

Below, Natural Polypro version of the 50 cubic inch PDS.

